

# Trailer Mount Parts Breakdown



Model #TLR-175

**MAXIMUM LOAD WEIGHT NOT TO EXCEED 240 LBS. GROSS**

## TRAILER MOUNT ASSEMBLY INSTRUCTIONS

**Step 1:** Insert axle through wheel and axle weldment.

**Step 2:** Put washer on, then install hair pin clip to secure axle. Repeat Steps 1 and 2 for other side.

**Step 3:** Bolt tube support on axle weldment.

**Step 4:** Insert trailer tongue per drawing and pin into position.

**Step 5:** Insert spreader mount into opposite side of trailer tongue and pin into position.

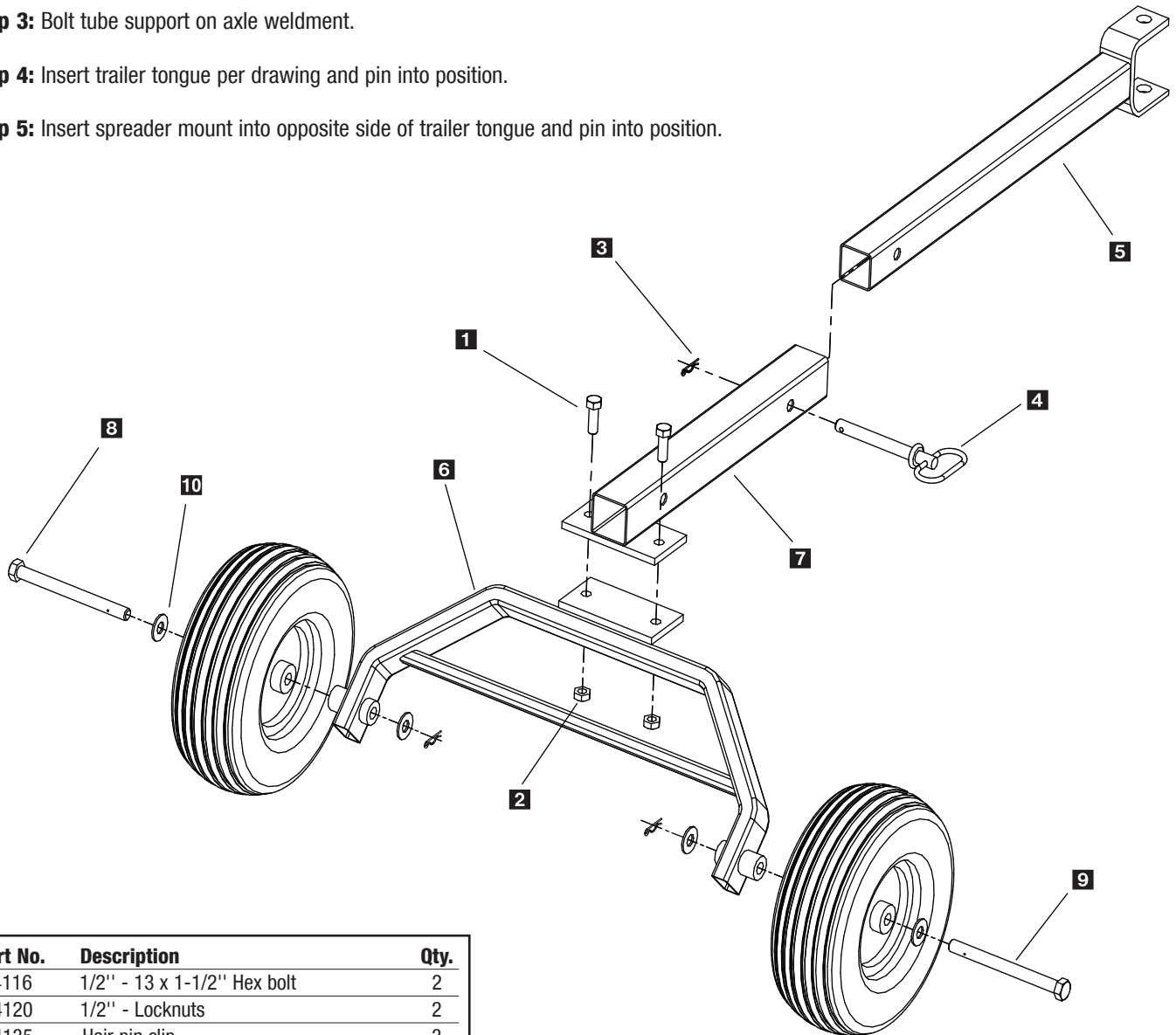

Key	Part No.	Description	Qty.
1	D 4116	1/2" - 13 x 1-1/2" Hex bolt	2
2	D 4120	1/2" - Locknuts	2
3	D 4135	Hair pin clip	3
4	D 4136	5/8" x 5 -1/2" Hitch pin	1
5	D 6438	Trailer tongue	1
6	D 6439	Trailer "A" frame	1
7	D 6440	Receiver tube mount	1
8	D 6441	Trailer tire	2
9	D 6442	5/8" - 13 x 7" Hex bolt special	2
10	D 6443	5/8" Flat washers	4