

A DIV. OF NORTHERN STAR INDUSTRIES, INC.
P.O. BOX 788 IRON MOUNTAIN, MICHIGAN 49801

**1973 - 1993 DODGE W250 & W350
RT3 UNDERCARRIAGE
MOUNTING INSTRUCTIONS
(PART NO. LTA03669)**

PUTS SNOW IN ITS PLACE

MSC04025-1

WARNING

Many newer trucks are now equipped with air bags. DO NOT under any circumstances disable, remove or relocate any sensors or other components related to the operation of the air bags.

Always follow the vehicle manufacturers' recommendations relating to snowplow installation. For recommended vehicle models refer to the Boss Snowplow Application Chart and Selection Guide.

1973 - 1993 DODGE W250 & W350 RT3 UNDERCARRIAGE MOUNTING INSTRUCTIONS

The mounting procedure outlined below covers 1973 - 1993 Dodge W250 & W350 trucks. You will need to refer to the illustrations and familiarize yourself with each of the undercarriage components and their relative position to each other. Then proceed as follows:

1. Remove the Front Bumper and Front Bumper Mounting Brackets from the Frame Horns. Unbolt each of the Front Bumper Mounting Brackets from the Front Bumper.
 2. Drill the triangular pattern of holes on Frame Horns and Front Bumper Mounting Brackets to 9/16" diameter.
 3. Position the PUSH BEAM SUPPORT PLATES (Ref. 62A and 62B, Fig. 1) and Front Bumper Mounting Brackets on the Frame Horn and attach using 1/2" – 13 x 2" HEX HEAD BOLTS, 1/2" – 13 HEX HEAD SELF LOCKING NUTS, and 1/2" FLAT WASHERS as shown in Figure 1. Note that 3 bolts attach through the side of the Frame Horn, and one bolt through the top of the Frame Horn.
 4. Position the PUSH BEAM (Ref. 62, Fig 1) between the PUSH BEAM SUPPORT PLATES using 5/8" – 11 x 2" HEX HEAD BOLTS and 5/8" – 11 HEX HEAD SELF-LOCKING NUTS.
- NOTE: The proper height adjustment for the PUSH BEAM is approximately 15-1/2" from the ground to the center of the PUSH BEAM pin-receiving hole (See Figure 2).
5. Position the ANGLE BRACKET (RH) (Ref. 75R, Fig. 1) between the frame rail and PUSH BEAM SUPPORT PLATE. Bolt the ANGLE BRACKET to the PUSH BEAM SUPPORT PLATE using 5/8" – 11 x 2" HEX HEAD BOLTS and SELF-LOCKING NUTS.
 6. Push the frame end of the ANGLE BRACKET tightly against the frame. Bolt the ANGLE BRACKET to the frame using 5/8" – 11 x 2" HEX HEAD BOLTS, 5/8" – 11 FLAT WASHERS and 5/8" – 11 SELF-LOCKING NUTS.
 7. Install the ANGLE BRACKET (LH) (Ref. 75L, Fig 1) following the same procedure as steps 5 and 6 above.
 8. Torque all fasteners to the values specified in Figure 3.

1993 & OLDER DODGE W250 & W350 RT3 UNDERCARRIAGE INSTALLATION PROCEDURE

REF. NO.	DESCRIPTION	PART NO.	QTY.
62	Push Beam Assembly	PBA03670	1
62A	Push Beam Support Plate (RH)	LTA03615	1
62B	Push Beam Support Plate (LH)	LTA03617	1
75R	Angle Bracket (RH)	LTA03619	1
75L	Angle Bracket (LH)	LTA03622	1
	FASTENER KIT, DODGE 91-93	HDW05524	1
Includes:			
A	5/8" – 11 x 2" Hex Head Bolt	HDW01731	14
B	5/8" – 11 Hex Head Self Locking Nut	HDW01709	14
C	1/2" – 13 x 2" Hex Head Bolt	HDW01755	8
D	1/2" – 13 Hex Head Self Locking Nut	HDW01748	8
E	1/2" Hardened Washer	HDW05501	8
F	5/8" Lock Washer	HDW03891	4

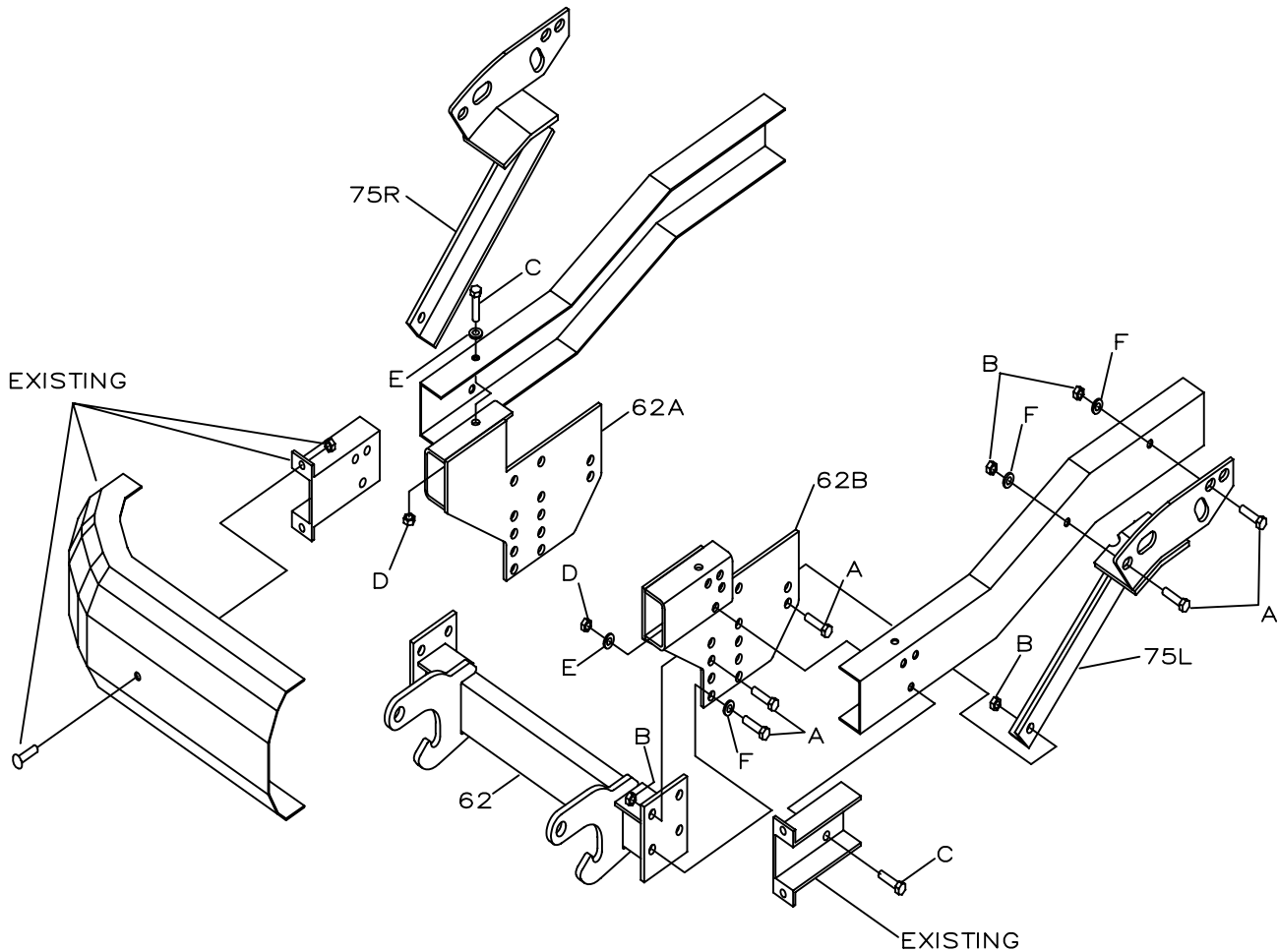

Figure 1

RECOMMENDED PUSHBEAM HEIGHT

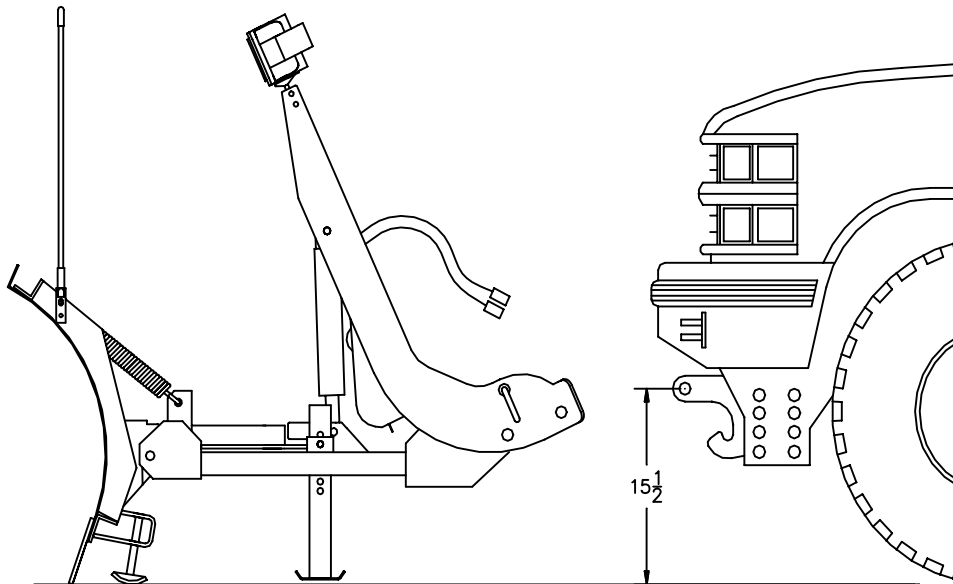

Figure 2

GUIDE TO RECOMMENDED ASSEMBLY TORQUE

All Torque Values Are In Foot-Pounds (Ft.-Lb.)

DIA./PITCH	GRADE 5	GRADE 8
1/4 - 20	6	9
5/16 - 18	14	19
3/8 - 16	23	33
7/16 - 14	38	53
1/2 - 13	56	80
M14 X 2.00	80	112
9/16 - 12	82	116
5/8 - 11	113	159
3/4 - 10	201	283

* The torque values listed above are based on dry, coated bolts, variables such as oil, or other lubrications may appreciably alter these values and must be taken into consideration.

NOTE: IT IS IMPORTANT THAT ALL FASTENERS BE PROPERLY TORQUED TO ASSURE A SAFE OPERATING PLOW.

Figure 3