

A DIV. OF NORTHERN STAR INDUSTRIES, INC.
P.O. BOX 788 IRON MOUNTAIN, MICHIGAN 49801

**1994 & NEWER DODGE
RT3 UNDERCARRIAGE
MOUNTING INSTRUCTIONS
(PART NO. LTA3666E)**

PUTS SNOW IN ITS PLACE

MSC04014-6

WARNING

Many newer trucks are now equipped with air bags. DO NOT under any circumstances disable, remove or relocate any sensors or other components related to the operation of the air bags.

Always follow the vehicle manufacturers' recommendations relating to snowplow installation. For recommended vehicle models refer to the Boss Snowplow Application Chart and Selection Guide.

1994 & NEWER DODGE RT3 UNDERCARRIAGE MOUNTING INSTRUCTIONS

The mounting procedure outlined below covers 1994 & newer 4 X 4 DODGE $\frac{3}{4}$ and 1 ton and 1994 - 1996 4 X 4 DODGE $\frac{1}{2}$ ton trucks. You will need to refer to the illustrations and familiarize yourself with each of the undercarriage components and their relative position to each other. Then proceed as follows:

1. Loosen and remove the bolt bar (existing item AA, see Fig. 1) from the frame/bumper mounting tab. Loosen and remove the single bolt from the frame/bumper mounting tab (existing item BB, see Fig. 1). Loosen, remove and discard the bolt from the corner bumper brace. This item will be replaced by item G (see Fig. 1). When re-using the bolt bar (on 1997 & newer vehicles) insert the bar from the center of the vehicle outward. Only (1) stud of the bolt bar will be securing the PUSHBEAM SUPPORT PLATES (Ref. 62A and B, Fig. 1). Installing the bolt bar as described will allow the nuts to be re-tightened on two different surface levels. Position the PUSH BEAM SUPPORT PLATES (Ref. 62A and 62B, Fig. 1) to the front frame rails of the truck. Using the vehicles existing bumper bracket hardware and item G bolts, bolt the PUSH BEAM SUPPORT PLATES in place (see Fig. 1). Fasteners should only be finger tight.
2. Bolt the PUSH BEAM (Ref. 62, Fig. 1) in place using the 1/2" - 13 x 1-1/2" hex head bolts and self-locking nuts provided. NOTE: the proper height adjustment for the PUSH BEAM is approximately 15-1/2" from the ground to the center of the PUSH BEAM pin-receiving hole (see Fig. 2). Should the PUSH BEAM ASSEMBLY be mounted too high, the nose of the plow will tend to dig in while plowing. If the PUSH BEAM ASSEMBLY is mounted too low the wings of the plow will not lay flat against the ground. This will be most apparent when plowing in the scoop position.
3. Install the LEFT ANGLE BRACKET (Ref. 75B, Fig.1) from the mounting points on the PUSH BEAM to the truck frame. On some models it may be necessary to drill the frame for the lower hole (see Fig. 1). Using the 1/2" - 13 x 1-1/2" hex head bolts, 1/2" - 13 U-bolt (Ref. D, Fig. 1) and self-locking nuts, secure the LEFT ANGLE BRACKET to the PUSH BEAM and the vehicle frame. Fasteners should only be finger tight.

4. Install the RIGHT ANGLE BRACKET (Ref. 75A, Fig. 1) from the mounting points on the PUSH BEAM to the truck frame. Using the 1/2" - 13 x 1-1/2" hex head bolts, the 1/2" - 13 self locking nuts, the 5/8" - 11 x 5" hex head bolt and self locking nut (Ref. E & F, Fig. 1), secure the RIGHT ANGLE BRACKET to the PUSH BEAM and the vehicle frame. Fasteners should only be finger tight.

5. Check that the Pushbeam Support Plates are level with the ground and reposition as necessary. With all undercarriage parts in place, securely fasten all mounting hardware. It is important that all fasteners be properly torqued (see Fig. 3) to assure a safe operating plow. Re-tighten all fasteners after 2 hours of plowing.

1994 & NEWER DODGE UNDERCARRIAGE INSTALLATION PROCEDURE

REF. NO.	DESCRIPTION	PART NO.	QTY.
62	Push Beam Assembly	PBA3665	1
62A	Push Beam Support Plate (RH)	PBA2206	1
62B	Push Beam Support Plate (LH)	PBA2207	1
75A	Angle Bracket (RH)	MTA2221	1
75B	Angle Bracket (LH)	MTA2222	1
	FASTENER IT, DODGE 94&UP	HDW01788	1
Includes:			
A	1/2" – 13 X 1-1/2" Hex Head Bolt	HDW01728	12
B	1/2" – 13 Hex Head Self Locking Nut	HDW01748	14
C	1/2" Flat Washer	HDW01729	2
D	1/2" "U" – Bolt	HDW05504	1
E	5/8" – 11 X 5" Hex Head Bolt	HDW01747	1
F	5/8" – 11 Hex Head Self Locking Nut	HDW01709	1
G	7/16" – 14 X 1-1/2" Hex Head Bolt	HDW01799	2

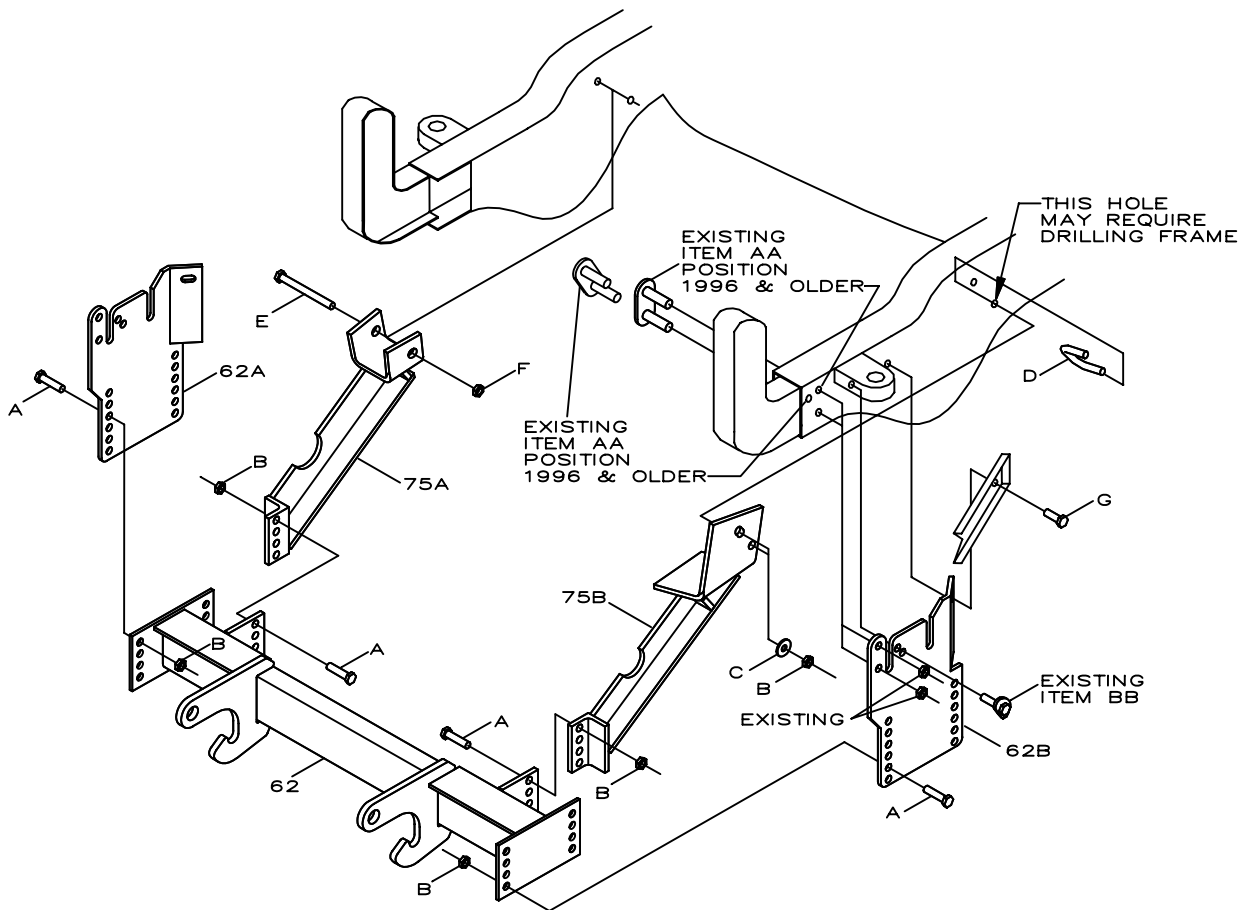

Figure 1

RECOMMENDED PUSHBEAM HEIGHT

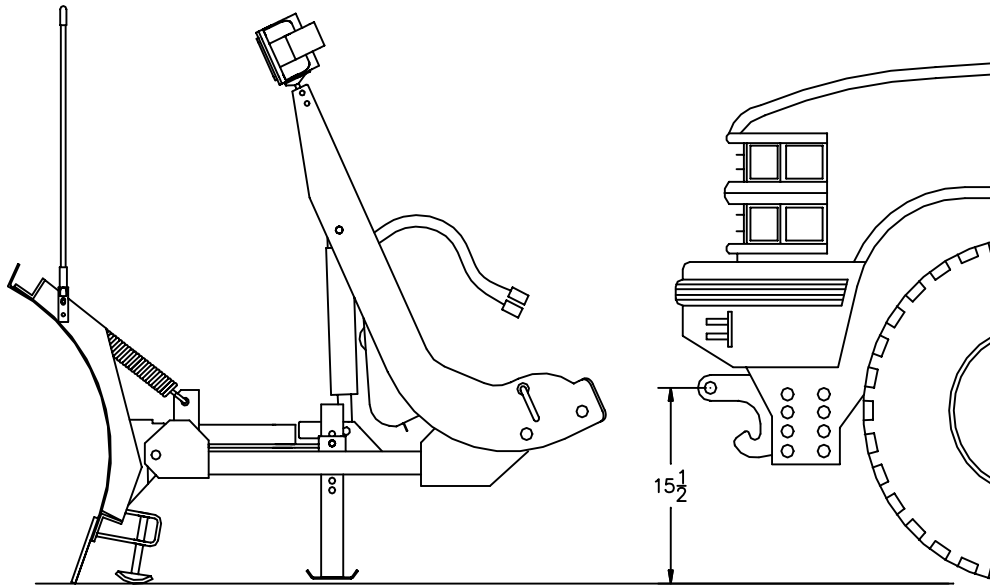

Figure 2

GUIDE TO RECOMMENDED ASSEMBLY TORQUE

All Torque Values Are In Foot-Pounds (Ft.-Lb.)

DIA./PITCH	GRADE 5	GRADE 8
1/4 - 20	6	9
5/16 - 18	14	19
3/8 - 16	23	33
7/16 - 14	38	53
1/2 - 13	56	80
M14 X 2.00	80	112
9/16 - 12	82	116
5/8 - 11	113	159
3/4 - 10	201	283

* The torque values listed above are based on dry, coated bolts, variables such as oil, or other lubrications may appreciably alter these values and must be taken into consideration.

NOTE: IT IS IMPORTANT THAT ALL FASTENERS BE PROPERLY TORQUED TO ASSURE A SAFE OPERATING FLOW.

Figure 3